

5' V-RACK HORSE



FEEDER

ASSEMBLY INSTRUCTIONS

#035-50000

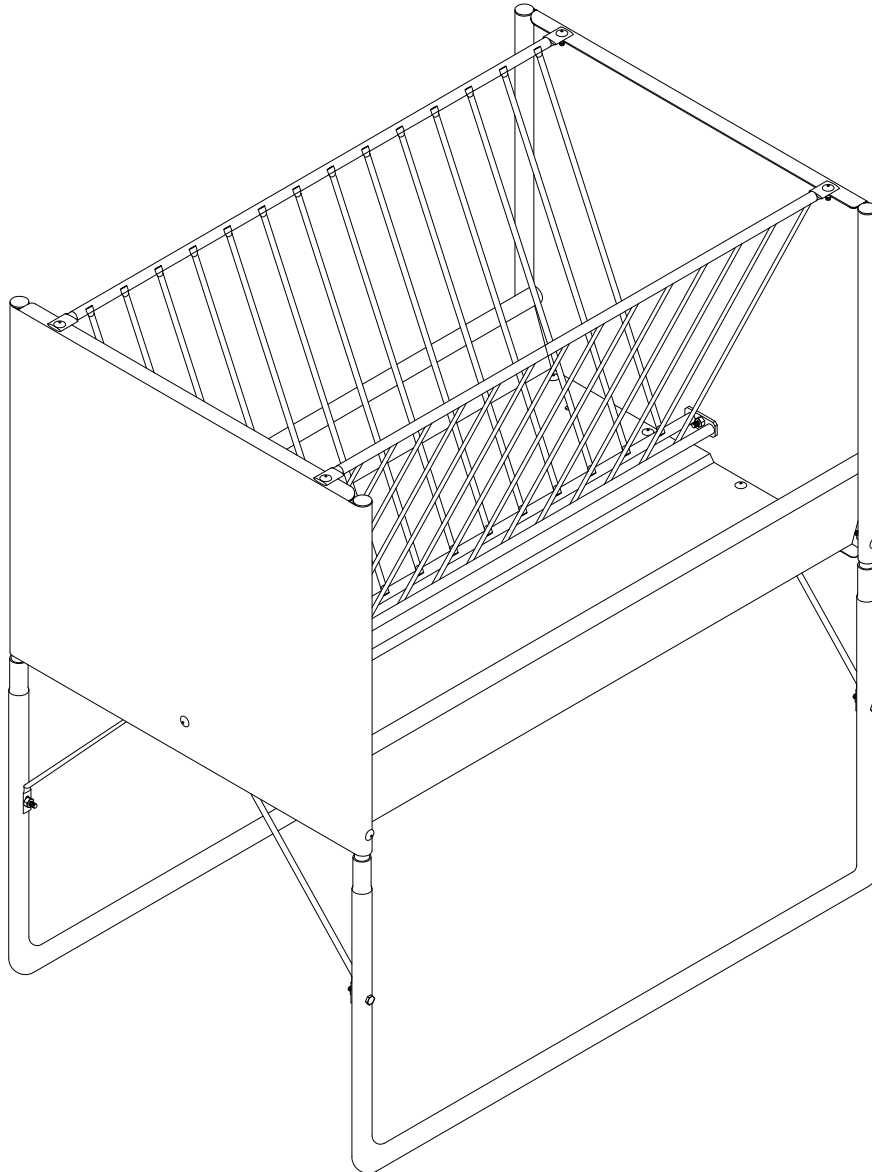

POWDER RIVER

• LIVESTOCK HANDLING EQUIPMENT •

www.powderriver.com

1-800-453-5318

NOTE: It will take two people to assemble the horse feeder.

STEP 1:

Slide the two End Panels onto the Feeder Legs, with the (4) slotted holes on the bottom of each panel, and the rolled edges on each panel facing inside the feeder as shown in figure 1.

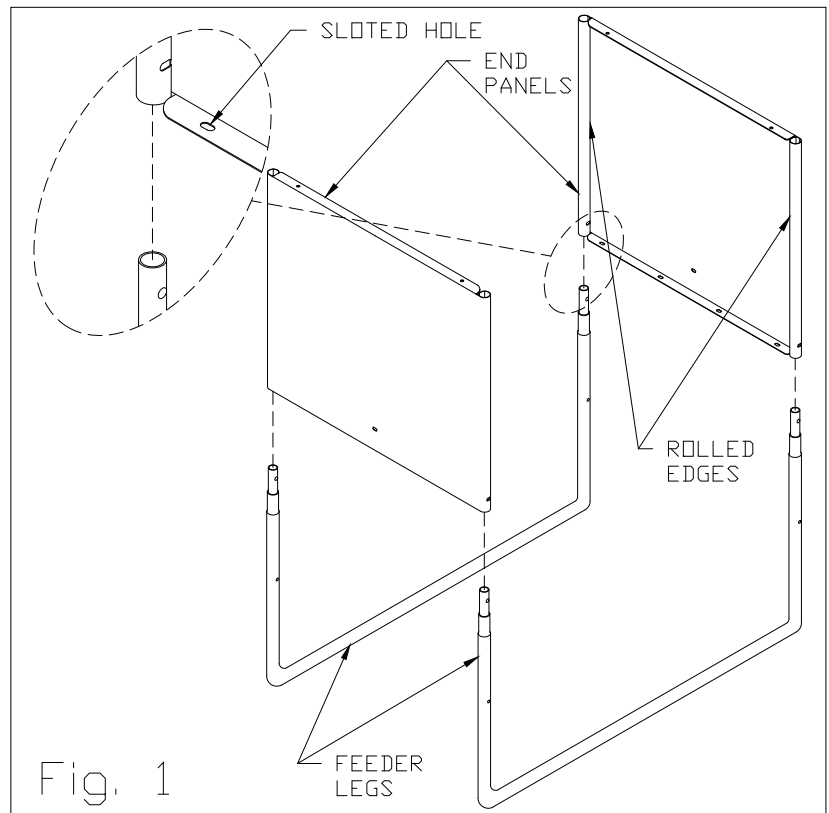

Fig. 1

STEP 2:

Secure the End Panel to the Feeder Legs with (4) 3/8" x 2" carriage bolts, and (4) 3/8" washers and lock nuts as shown in figure 2.

Slide the Feeder Bunk between the two End Panels and set it on top of the two bottom flanges as shown. Secure the Bunk to the End Panels with (4) 3/8" x 1" carriage bolts and (4) 3/8" washers and lock nuts, placed in the four outside slotted holes as shown into figure 2.

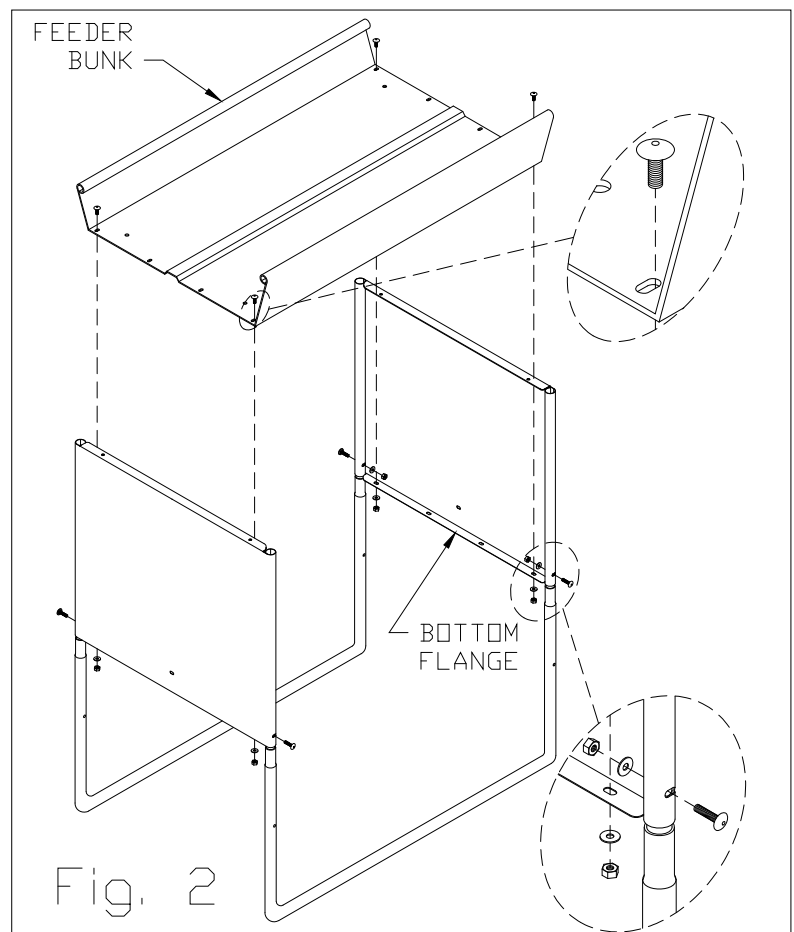
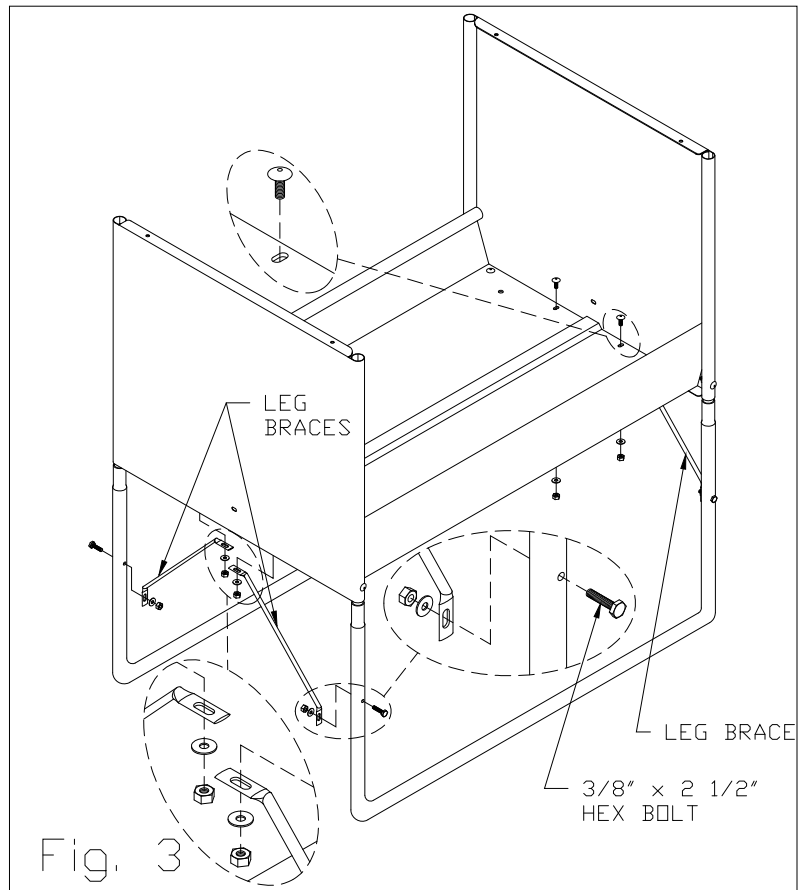

Fig. 2

POWDER RIVER
• LIVESTOCK HANDLING EQUIPMENT •

STEP 3:

Mount the four Leg Braces to the Feeder legs using (4) 3/8" x 2 1/2" hex bolts and (4) 3/8" washers and lock nuts, with the head of the bolt on the outside. Secure the tops of the Braces to the center holes on the Feeder Bunk with (4) 3/8" x 1" carriage bolts, and (4) 3/8" washers and lock nuts as shown in figure 3.

**STEP 4:**

Connect the V-Rack sides together as shown in figure 4.

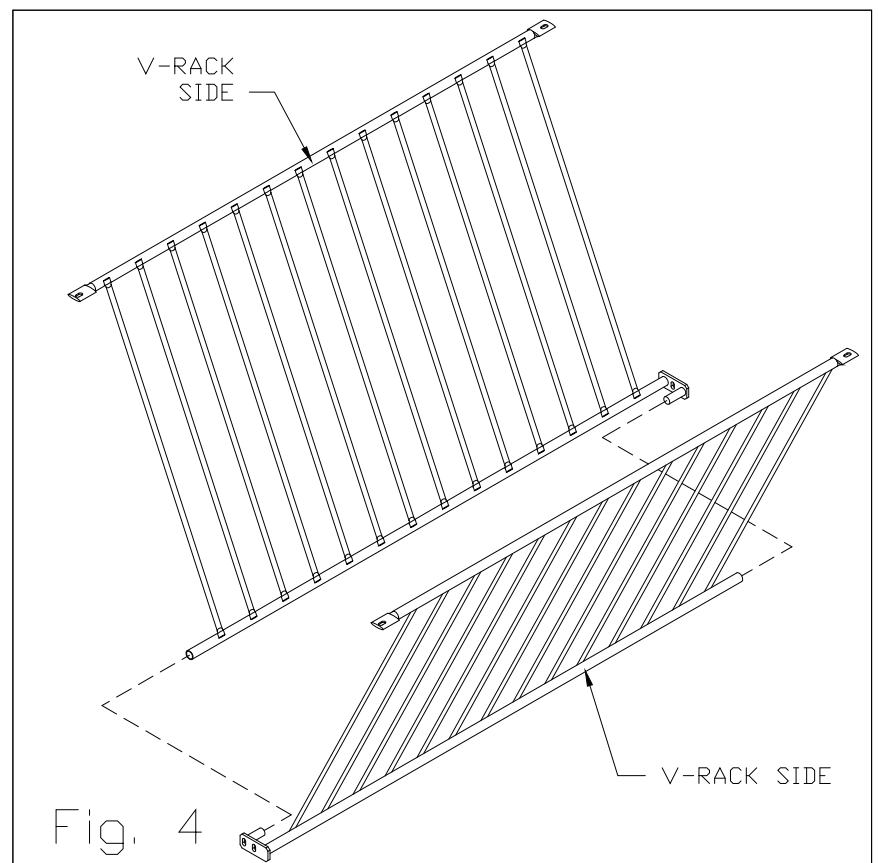

POWDER RIVER
 • LIVESTOCK HANDLING EQUIPMENT •

STEP 5:

Slide the bottom of the assembled V-Rack between the two End Panels and set the top of the V-Rack on the two top flanges of the End Panels. Fasten the V-Rack to End Panels with (6) 3/8" x 1" carriage bolts, and (6) 3/8" washers and lock nuts, as shown in figure 5.

Place the (4) plastic caps into the tops of the rolled edges of the End panels.

