

# 5' Poly Bunk and 5' V-Rack Feeder

## Assembly Instructions

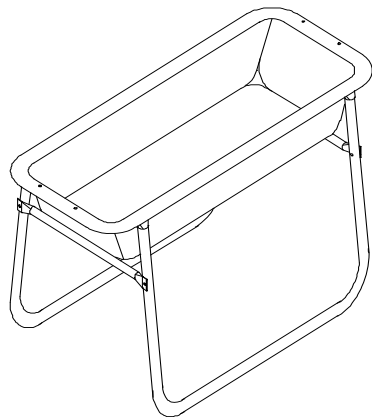

5' Poly Bunk with Skid  
035-60000



5' V-Rack Horse Poly Bunk  
035-60005

# POWDER RIVER

• LIVESTOCK HANDLING EQUIPMENT •

[www.powderriver.com](http://www.powderriver.com)

1-800-453-5318

**Step 1:**

Place the two bunk leg assemblies flat on the ground. They will be assembled upside down. Slide the legs together as shown.

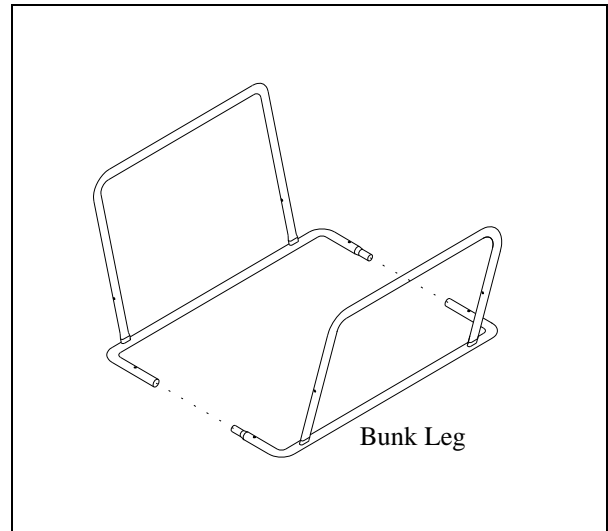

**Step 2:**

Flip the assembly over. This now forms a frame for the Poly Bunk. Slowly drop the Poly Bunk inside the bunk frame.

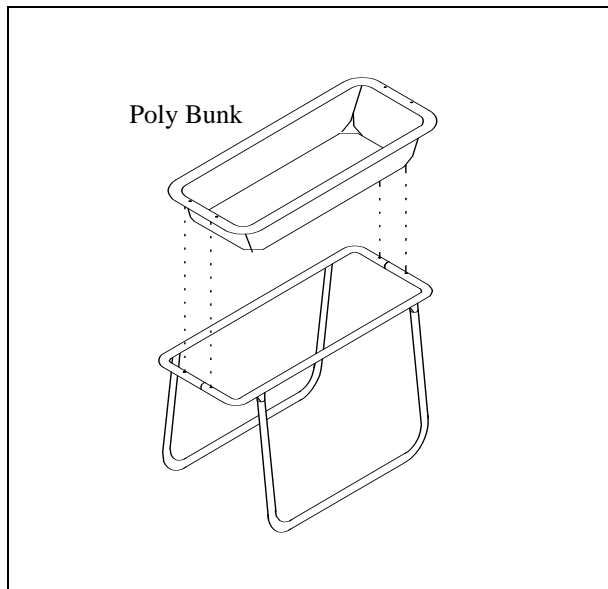

**Step 3:**

Slide each V-Rack Side over the V-Rack Ends as shown.

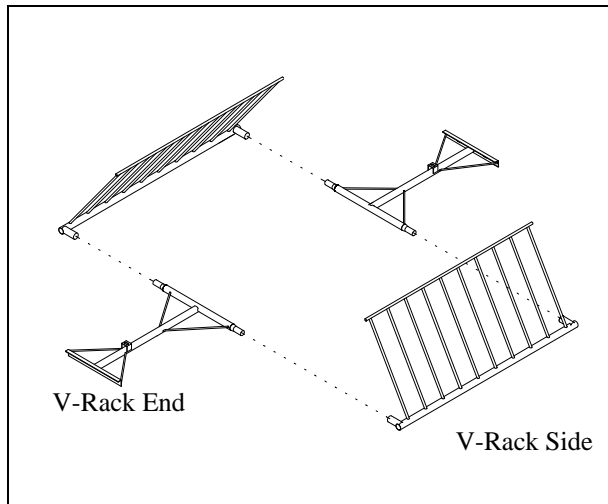

**Step 4:**

Swing the ends of the v-rack up, as shown, until the end of the rods fit inside the bracket on each end.

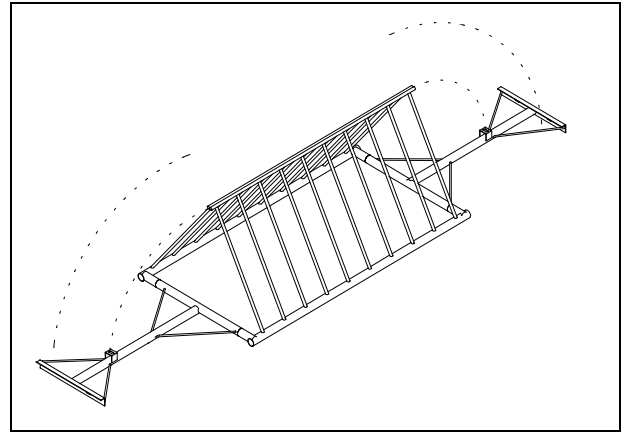
**Step 5:**

Flip the v-rack assembly over and bolt it to the bunk assembly using 3/8" x 2 1/2" hex bolts, washers, and nuts.

**Step 6:**

Bolt two poly bunk braces to each bunk end as shown using 3/8" X 2 1/2" hex bolts, washers, and nuts. Tighten all bolts to complete the assembly.

