

Notes:

Finger tighten bolts only during assembly. Do not tighten until Feeder is completely assembled.  
CAUTION: This assembly requires two individuals.

Contents:

- |                                 |  |                            |
|---------------------------------|--|----------------------------|
| 1 - 5' Bunk Only (035-00125)    | 2 - V-rack End Panels (035-00043)      | 1 - Bolt Bag (312-10435)   |
| 2 - V-rack Sides 5' (035-00038) | 2 - 5' Cattle Feeder Skids (035-00135) | 10 - Hex Bolt 3/8" X 1"    |
| 1 - 5' Skid Brace (035-00058)   |  | 4 - Hex Bolt 3/8" X 1 1/2" |
|                                 |  | 4 - Hex Bolt 3/8" X 2 1/2" |
|                                 |  | 18 - Hex Nut 3/8"          |
|                                 |  | 32 - Washer 3/8"           |

Instructions:

Step 1:

To begin the assembly, place the two skid ends on either side of the bottom brace. Align the holes on each end of the bottom brace to the mounting tabs in the center of each skid. Then using a 1" bolt, secure each end to the bottom brace.

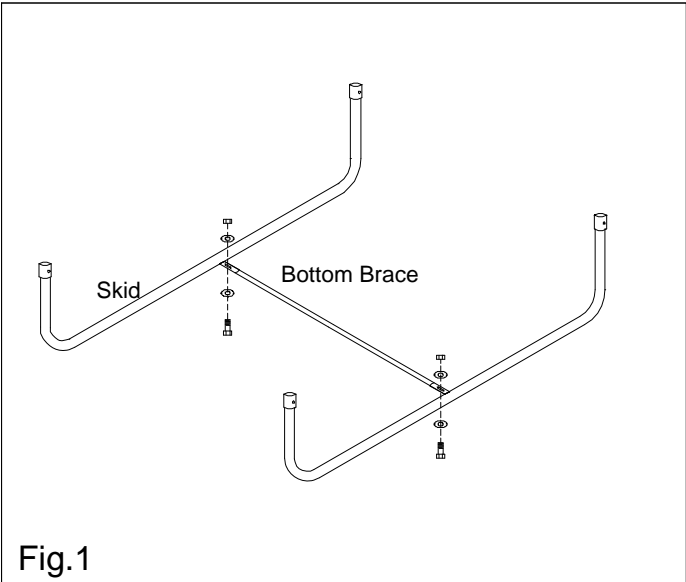

Step 2:

After bolting the skids to the bottom brace, set the assembly upright, as pictured in Fig. 1. Then slide each of the end panels over the skid ends. Bolt the end panels to the skids using 2 1/2" bolt.

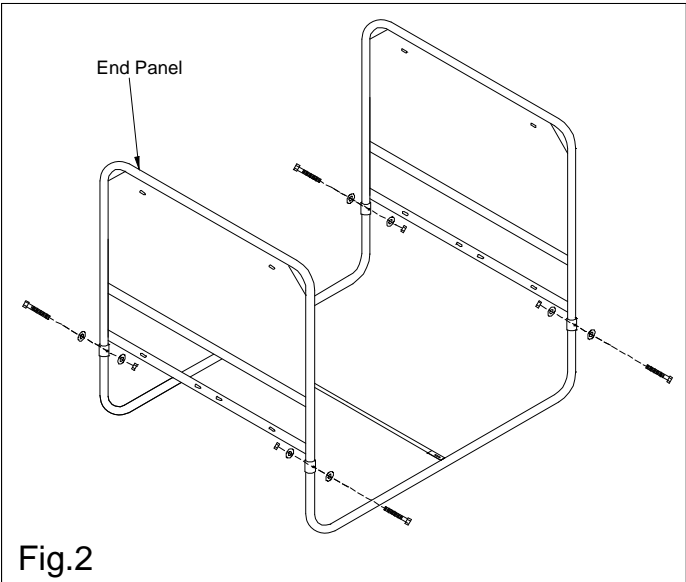

### Step 3:

Insert the feeder bunk by first placing one end of the bunk against the end panel. While bracing the bunk end slide the other end into place. Align all the holes on the bunk with the end panel. Secure the assembly in place by bolting the end panels to the bunk using the 1" bolts. Only bolt the two side holes. Do not insert the bolts into the two center holes on each end until step 4.

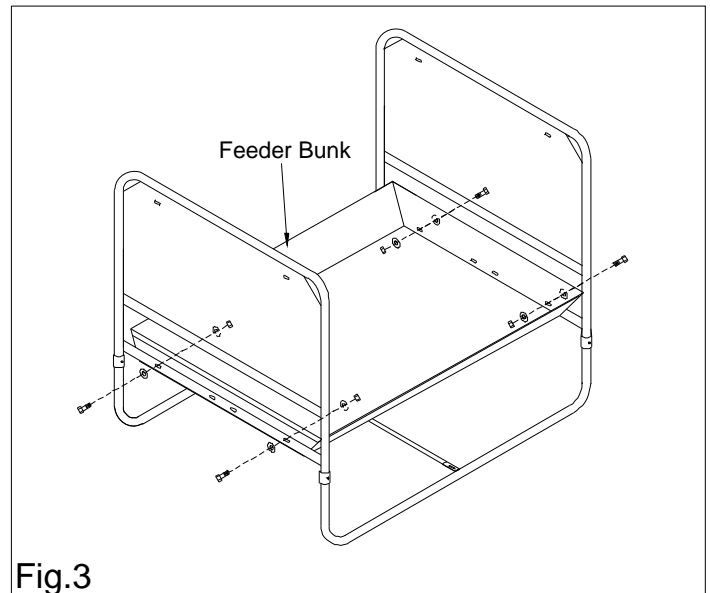

### Step 4:

After securing the bunk, insert each of the v-rack side pieces by aligning the top bar to two of the upper holes in each end panel. The welds on the sides should be placed toward the inside of the feeder. Bolt the top bar to the rack ends using 1" bolts. Pivot the side piece until the bottom bar is aligned with the bottom holes on the end panels. Using the 1 1/2" bolts, secure the skid braces, the skid, and the v-rack sides. Run the bolt through all three aligned holes. Repeat for the second rack side.

To complete the assembly, tighten all bolts.

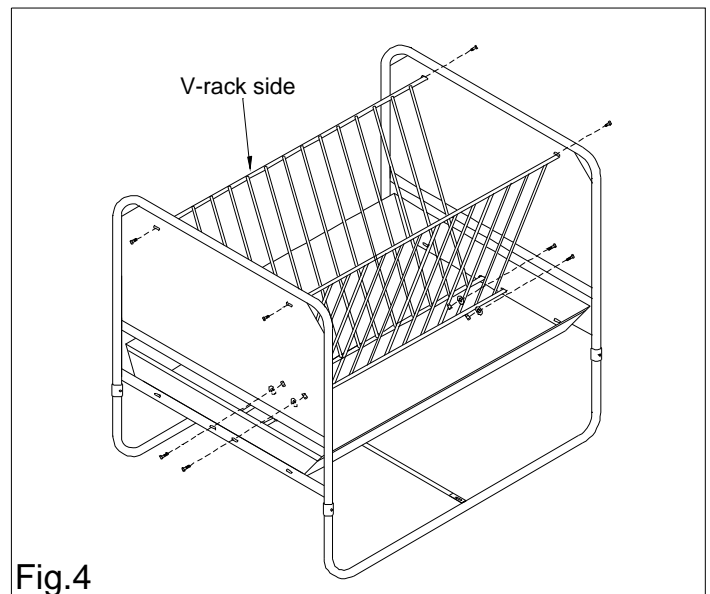

[www.powderriver.com](http://www.powderriver.com)

1-800-453-5318

12/02