

Manual Value Chute

Operating Instructions
#001-01003

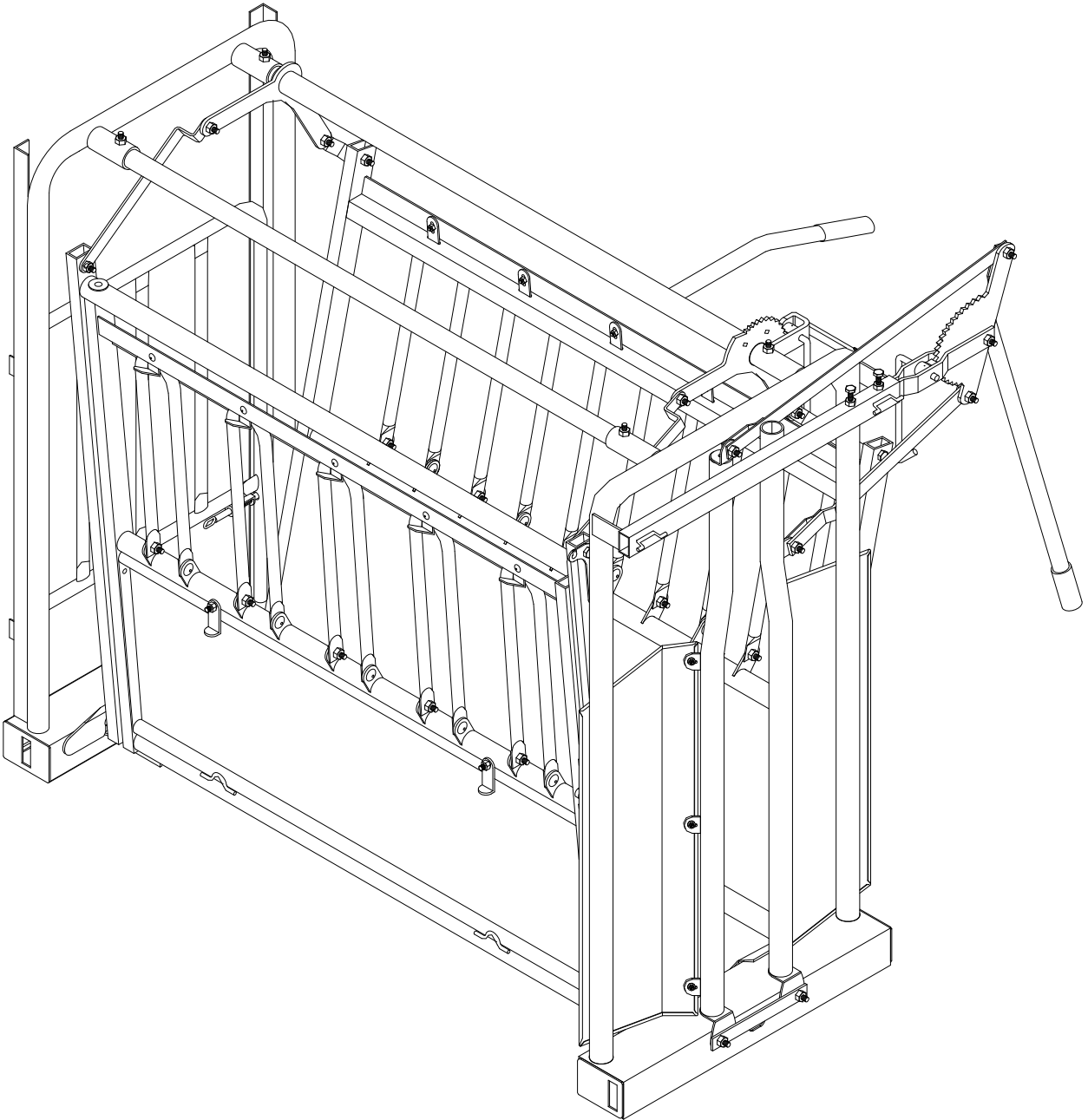

POWDER RIVER

• LIVESTOCK HANDLING EQUIPMENT •

www.powderriver.com

1-800-453-5318

We congratulate you on your purchase of the Powder River Manual Value Chute! Since 1938, we at Powder River have dedicated ourselves to making America's best livestock handling equipment. You have purchased just one of the many quality products made by Powder River. We are glad that you have chosen our product and hope you will repeat your business.

This guide will facilitate your use of the Manual Value Chute. If in the event you have problems that this guide cannot answer we invite you to contact us at www.powderriver.com or call us at (800) 453-5318.

Before Getting Started



Please be aware that incorrect use of this product may cause injury to you and/or to your animals. We advise you to take the necessary time to become familiar with the chute before actually operating it with animals. This will enable you to avoid potential injury to yourself and to your animals.

The Manual Value Chute

The Manual Value Chute is designed to hold livestock in an accessible position for branding, vaccinating, tagging, dehorning, and holding animals in a position to test for pregnancy, and overall inspection. Before using, the chute should be adjusted to accommodate the animals correctly.



Please be aware, the Manual Value Chute is engineered to use in working with **smaller, lighter, and more docile** animals. If you need a chute with heavy-duty capabilities, the Manual Value Chute may not be the best option for you. If you require a heavier chute for your operation, we recommend that you use our XL Chute, which is designed to be longer lasting under the most demanding conditions.

What You Will Need

To assemble, adjust, and operate your new Manual Value Chute you will need:

- A 5/16" and 3/4" socket
- A 5/8" wrench
- A hammer
- Lubricant spray

Getting Started

Before your Manual Value Chute can be put into use you will need to install the Stanchion Control Handle Assembly and loosen a number of the bolts that have been tightened for shipping purposes. (*You will only need to loosen the bolts enough to allow free movement of the chute joints. Do not completely remove the bolts or loosen them too much.*)

1. Remove the Stanchion Control Handle Assembly from inside the Chute.

Remove the two carriage bolts from the Long and Short Stanchion Straps, and loosen the two Set Screws on the Head Tube as shown in figure 1.

Slide the Stanchion Control Handle all the way into the Head Tube and tighten the Set Screws so that the Control Handle is secured to the Chute as shown in figures 1 and 2.

2. Secure the Long Stanchion Strap to the top bracket on the far Stanchion Pipe as shown in figure 2. Secure the Short Stanchion Strap to the arm mount on the Stanchion Pipe closed to the Control Handle as shown.

3. On each side of the Chute there are vertical fingers. Each finger is held into position by a finger latch on one end and two bolts on the opposite end, as shown in Figure 2. Each bolt holding the finger latch in place needs to be loosened enough to allow it to slide vertically. (*Generally you will only need to turn each of the bolts one to two full rotations.*) This will allow the finger latch to move up and down freely, so the fingers can easily drop down out of the way.

4. The kick panel is located below the fingers on both sides of the chute. It is also held into position by two latches, two for each kick panel as shown in figure 2. The kick pan latches need to be loosened to allow lowering the kick panel. These bolts are generally very tight and need to be turned only one full rotation or until the latch rotates freely.

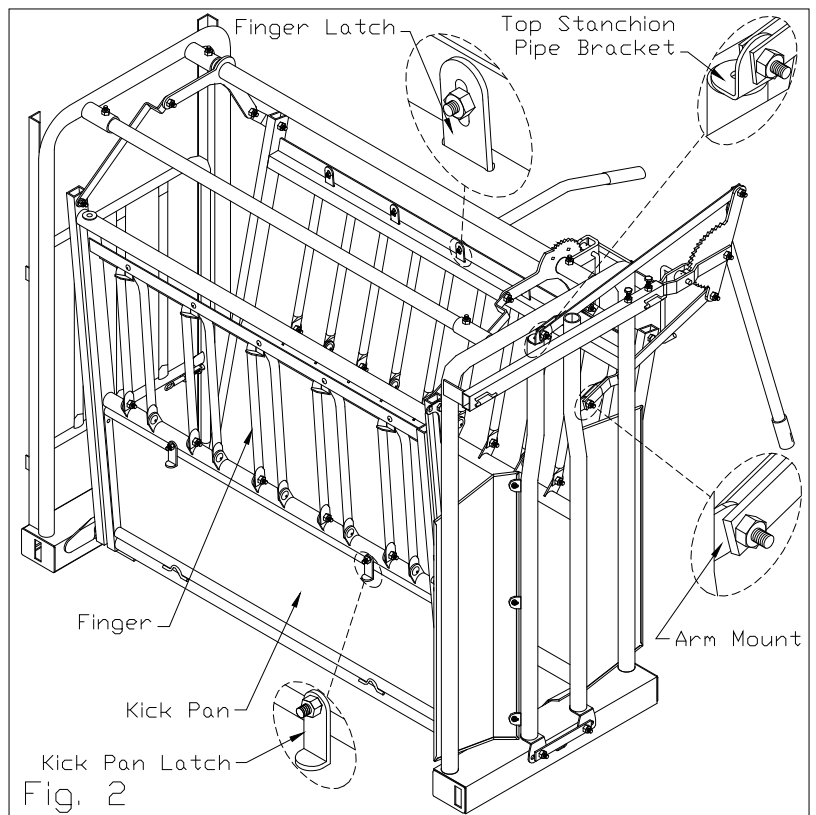
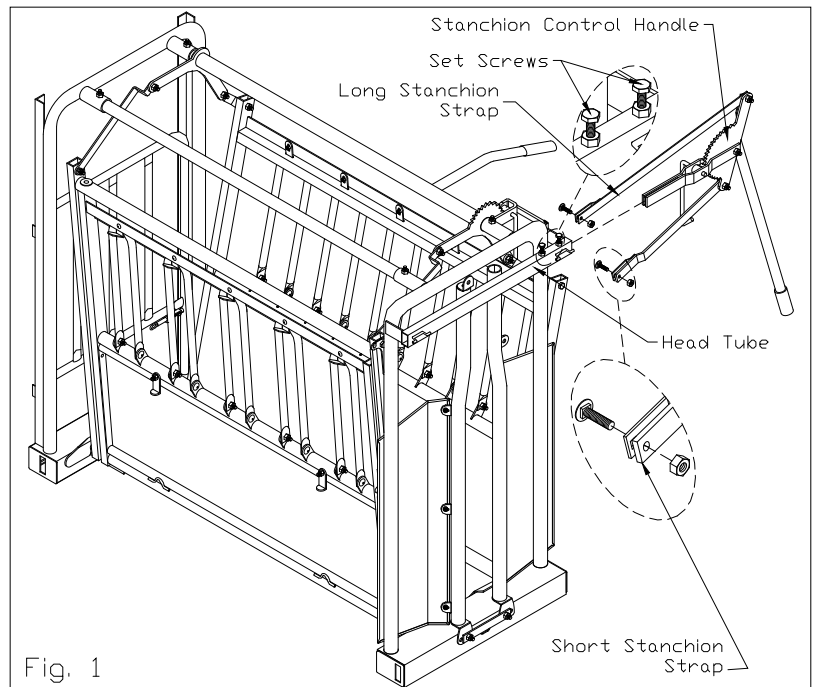

Set Up:

After all of the necessary bolts have been loosened the chute should be adjusted to accommodate the size of the animal. This is the most important step in setting up your chute. The Manual Value Chute can be adjusted in two ways. These adjustments change the size of the chute to better fit the size of the animal.

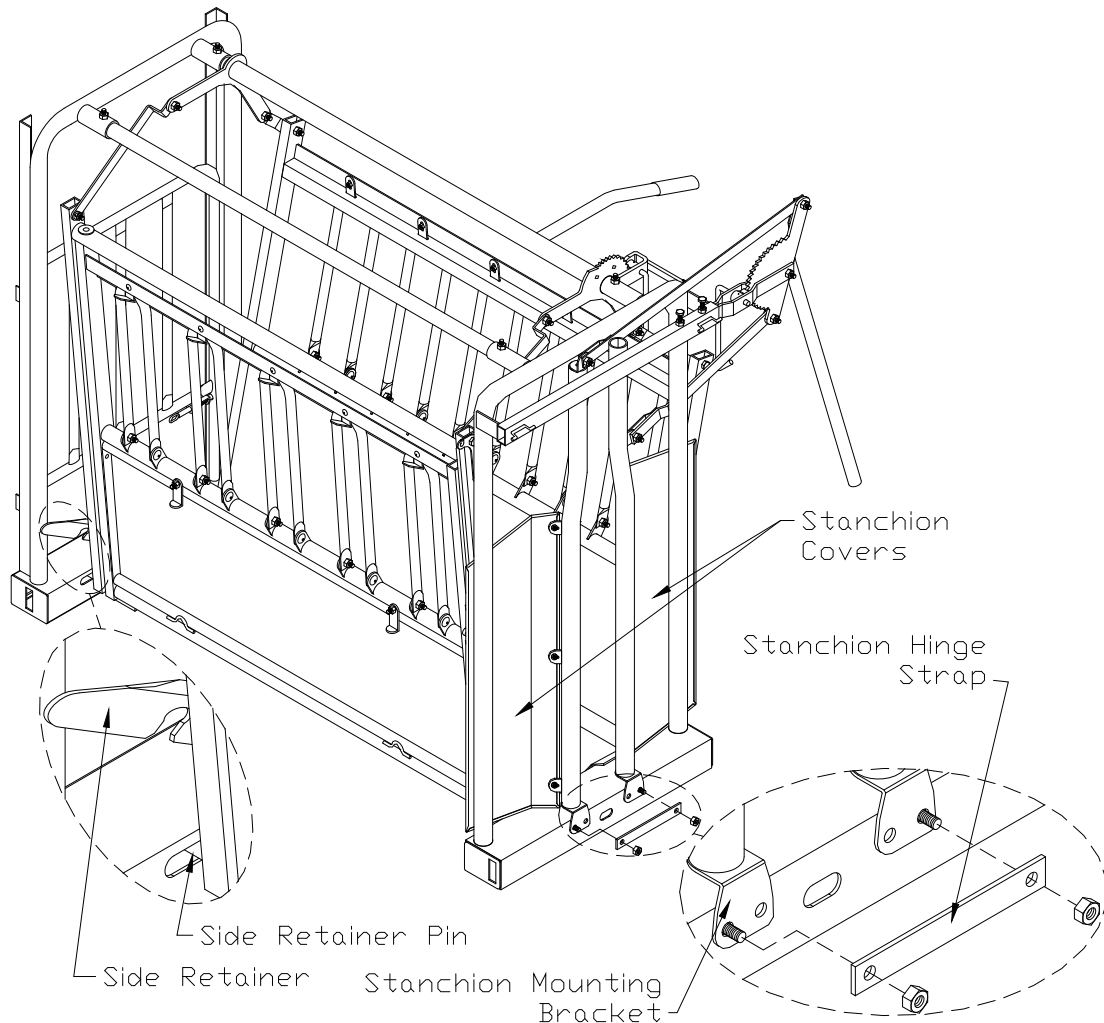

1. The first adjustment controls the width of the squeeze chute. Side retainers are found at the foot of the chute on both ends, as shown. The side retainer is a long, sloping bar, with three notched settings. The notches are designed to fit over the side retainer pin.

Lift both retainers on one side. After the retainer is raised, push or pull the side of the chute until the side retaining pin lines up with the desired notch of the side retainers. Once the chute's side is lined up with the desired notch lower the side retainers, fitting the slot over the side retainer pin. Pushing the chute side narrows the opening for smaller animals and pulling the side widens the chute for larger animals. Repeat this process on the other side of the chute until you reach the desired width of the chute.

2. The second adjustment changes the opening size of the head gate. By removing the Stanchion Hinge Strap at the bottom of the head gate, you're able to adjust the opening size of the Stanchion Covers. The outside hole on the Stanchion Mounting Bracket is for smaller animals and the inside hole is for larger animals. *(The headgate will come from the factory set in the narrow position.)*



The Manual Value Chute and its Working Parts

Before actually operating the Manual Value Chute with an animal we suggest that you become familiar with the working parts.

Tail Gate

The tailgate is located at the rear end of the chute. A rope is connected to the gate and strewn through a pulley. To raise the gate simply pull on the rope until the gate is completely raised, then release the rope completely. The gate will crash down after the rope has been let go, releasing the pin into a holding slot, holding the gate in the open position.

To lower the gate simply pull on the rope and lower the gate holding the rope until the holding pin has passed the holding slot then release the rope. The tailgate will drop into the closed position.

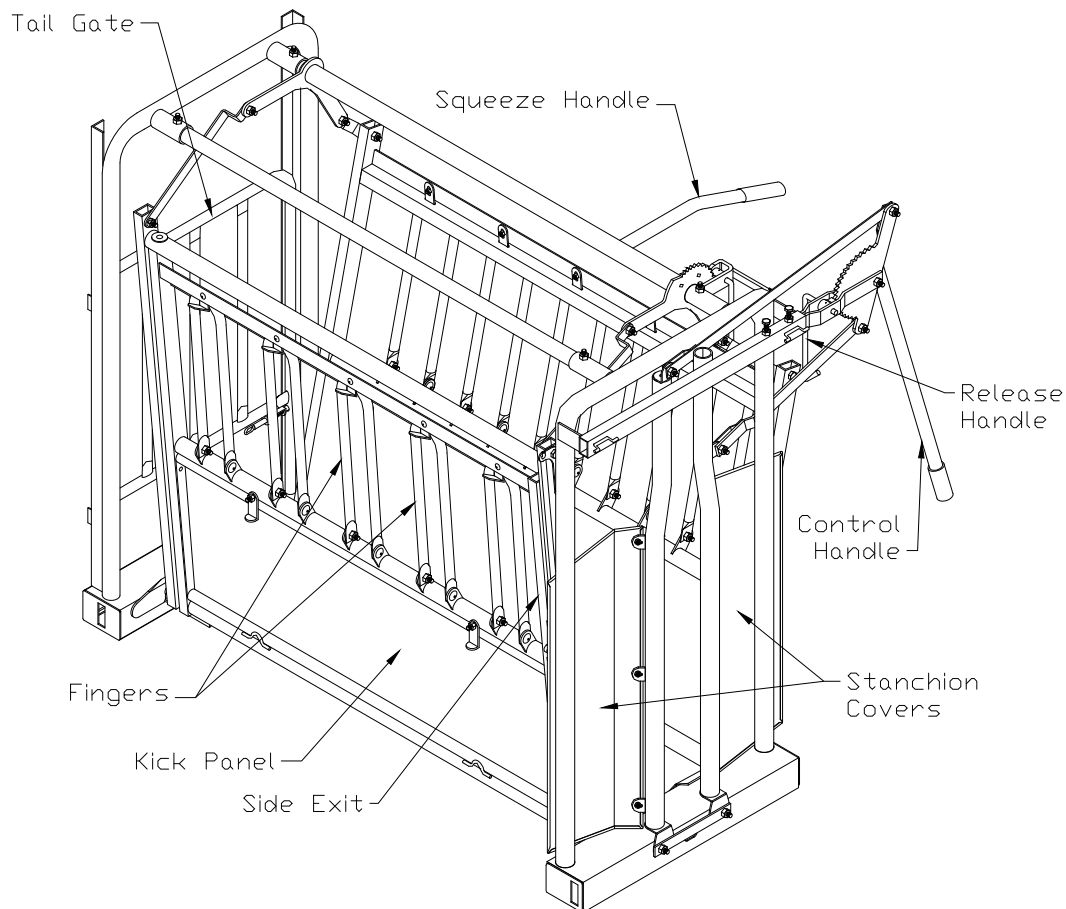

Head Gate

Perhaps the most important part of the squeeze chute is the head gate. The stanchion covers on the head gate are opened by pulling the Release Handle on the Stanchion Control Handle towards you and at the same time lifting up on the Control Handle, until the head gate is open approximately 3-4 inches wider than the head size of the animal.

With the tail gate and the head gate open, the animal is led into the chute where the tail gate is closed behind it and the front head gate closes as its head comes out the front of the Chute catching the animal between its head and shoulders. To close the head gate, simply pull down on the Stanchion Control Handle.



Kick Panel

The Kick Panel is designed to allow access to the legs and hooves of the cow. The Kick Panel runs along the bottom on both sides of the chute. Push the Kick Panel latch up and lower the Kick Panel by pulling it outward.

Squeeze Chute

The lever located on the side frame operates the actual squeezing of the chute. As the lever is pushed the squeeze is locked into position squeezing the animal. To release the animal, locate the release lever. The release lever is a small diameter green handle with a ninety-degree bend on the end of it. Pull this lever up to release the gears and pull the squeeze lever away from the animal. This will loosen the chute around the animal.

Side Exit

The side exit is a safety feature. This enables the operator to release an animal that won't exit out the front or for an animal that goes down to its knees while in the chute.

Located on the side frame is a ring tied to a rope. Pulling on the ring releases the side exit. After the ring is pulled the side exit will fall open, releasing the animal. To close the side exit, push the center squeeze handle down. This lifts the side enough that it will self-close.

Fingers

The fingers are designed to drop down to allow free access to the animal's sides. They are located on both sides of the chute. Push the finger latch up and lower the fingers by pulling them outward.

The Manual Value Chute and Replacement Parts

