

SYSTEM 2000
25' CLASSIC (RH) SWEEP TUB
ASSEMBLY INSTRUCTIONS
#007-50105

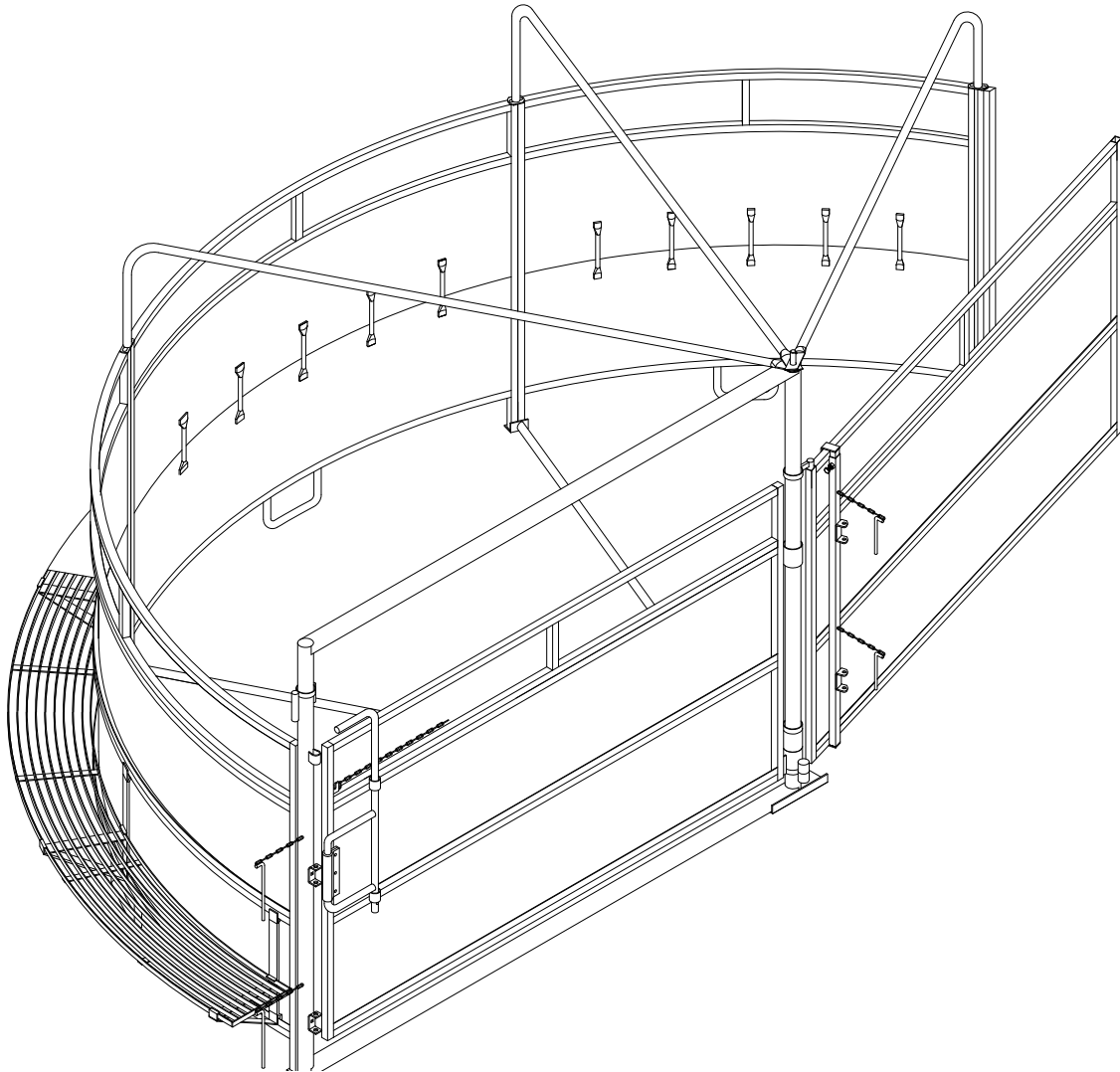

POWDER RIVER

• LIVESTOCK HANDLING EQUIPMENT •

www.powderriver.com

1-800-453-5318

Step 1:

To begin the assembly, locate the position where the desired center of the sweep tub will be located. Place the bottom brace mount flat on the ground near the center and using (3) 1/2" X 1-1/4" carriage bolts and 1/2" lock nuts, secure the bottom braces into place as shown in figure 1.

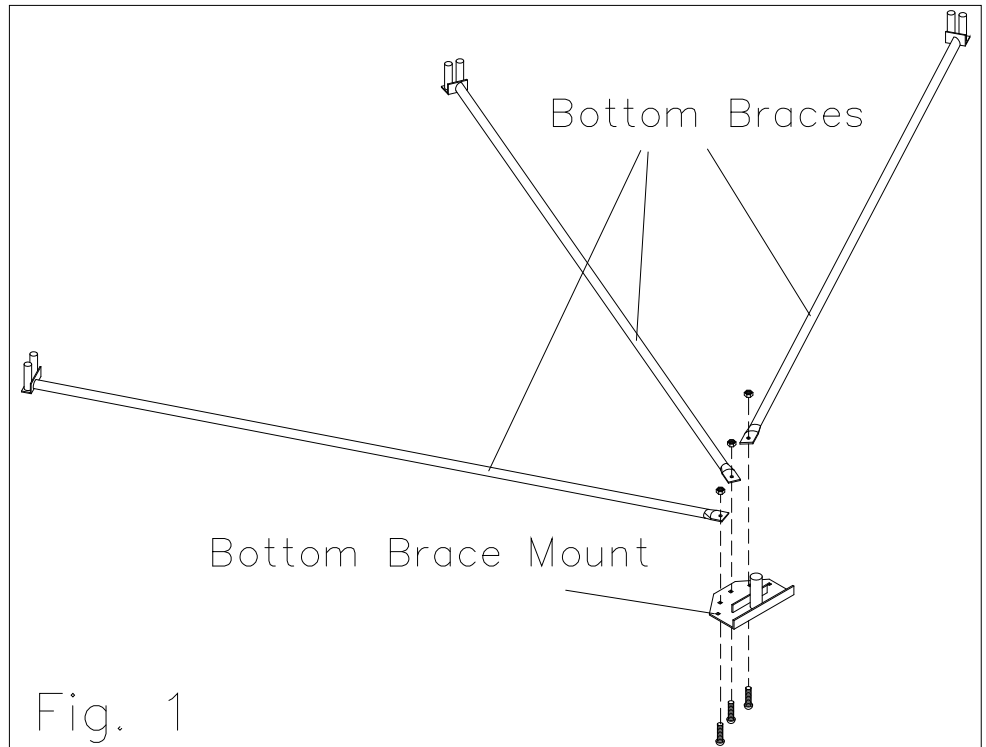

Step 2:

Using a forklift, lower the Sweep Bowgate gently. The end pipe of the Bowgate should slide gently over the pipe in the center of the Bottom Brace Mount as shown in figure 2. Unscrew the Hex Nut on the bottom of the hinge on the Bowgate and remove the 3/8" Hex Bolt from the hinge. This will allow the Sweep Bowgate to swing all the way around the sweep tub.

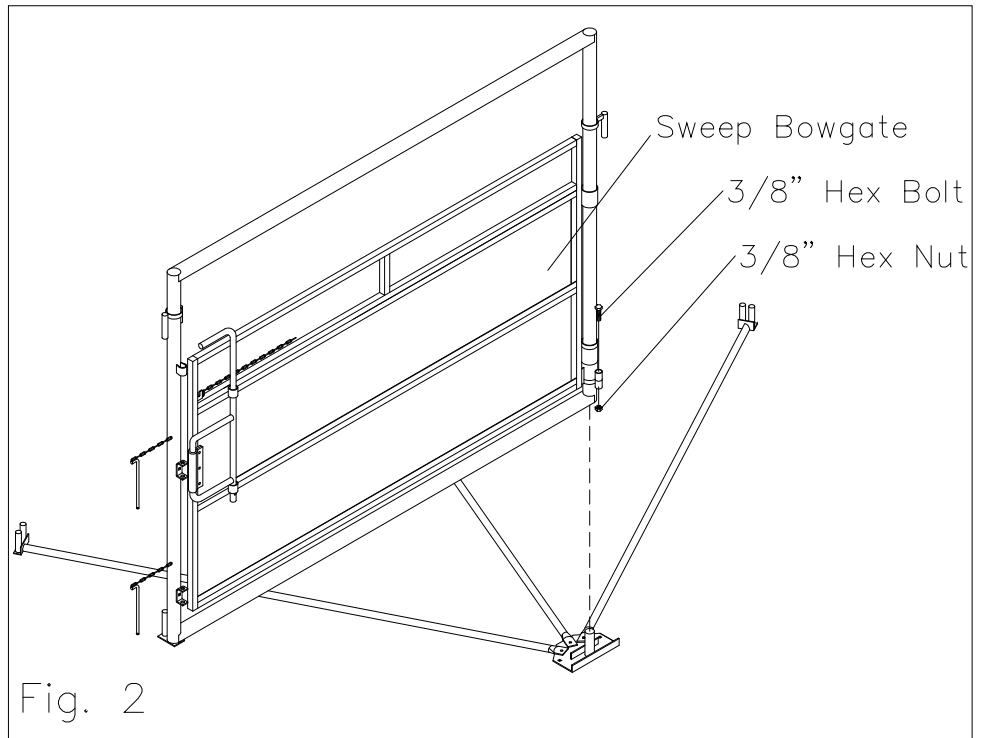

Step 3:

Next, using figure 3 as a reference, lower each of the sweep panels into place. Starting at the left side of the Bowgate, slide the endpost of each of the three Curved Sweep Panels over the protruding connector pegs on the Bottom Braces.

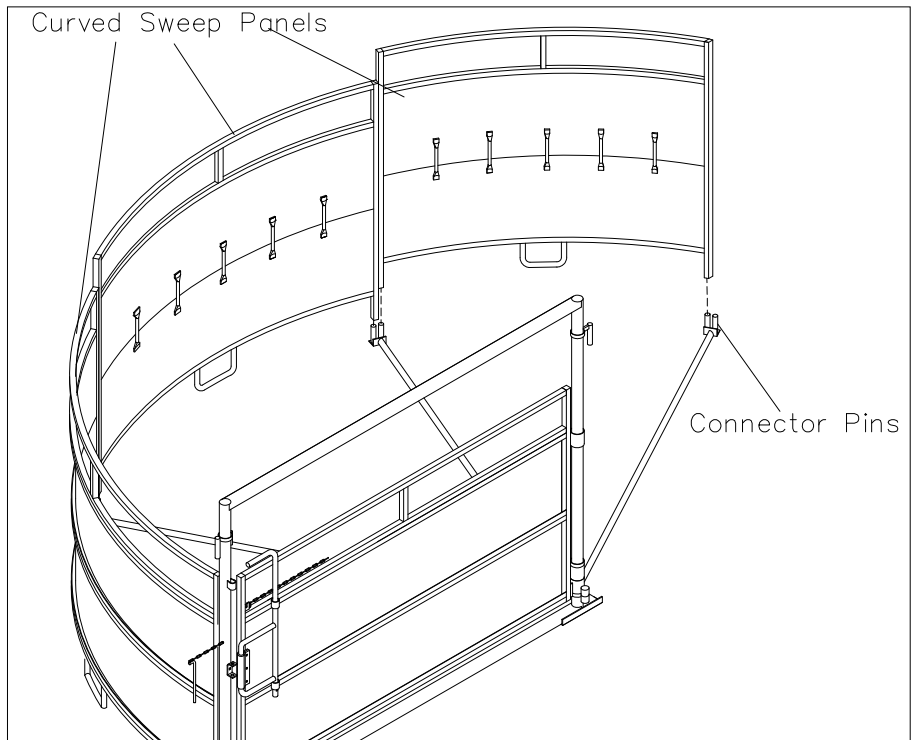

Step 4:

Now lower the longer tube of the Sweep to Alley Adaptor over the remaining Bottom Brace connector pin as shown in figure 4

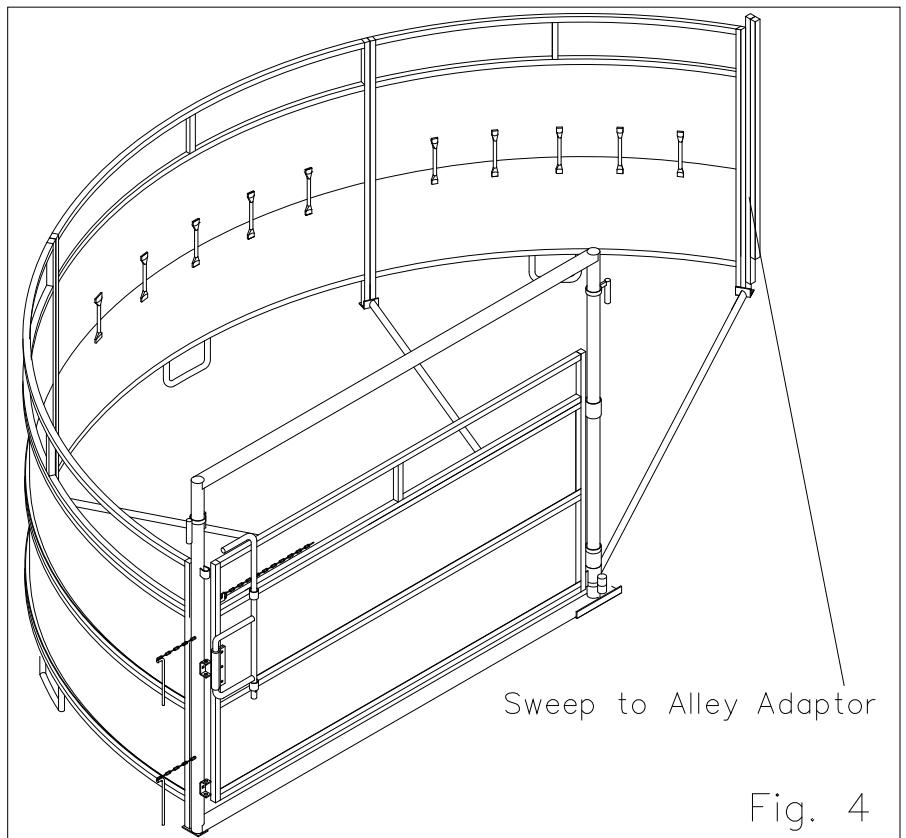

Step 5:

To complete the Sweep Tub portion of the assembly, lower the Sweep Top Brace Mount into the top of the Bowgate endpost. Then lower each of the Top Braces over the pipe on top of the Top Brace Mount and slide the connector pins on the ends of the Top Braces into the Sweep Panel endposts as shown in figure 5.

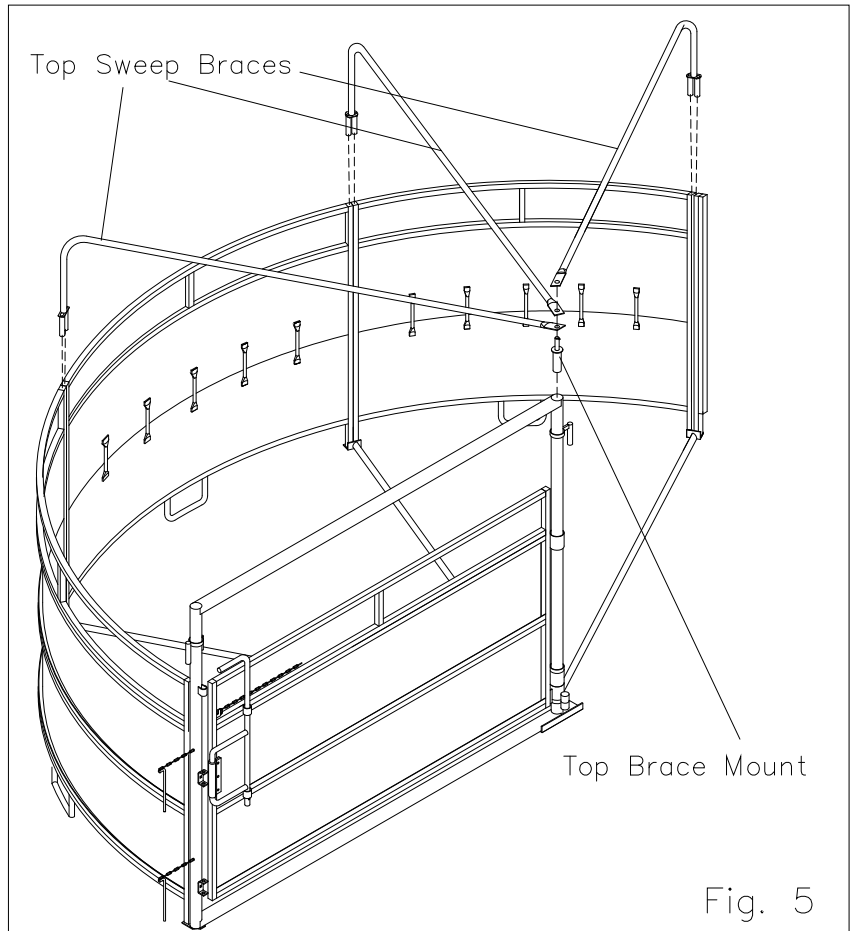

Step 6:

Lift the Bowgate Connecting Pin up and lower the Straight Alley Panel into place. Lower it over the connecting pin at the bottom of the Sweep Bowgate and then lower the Top Bowgate Connecting Pin into place as shown in figure 6.

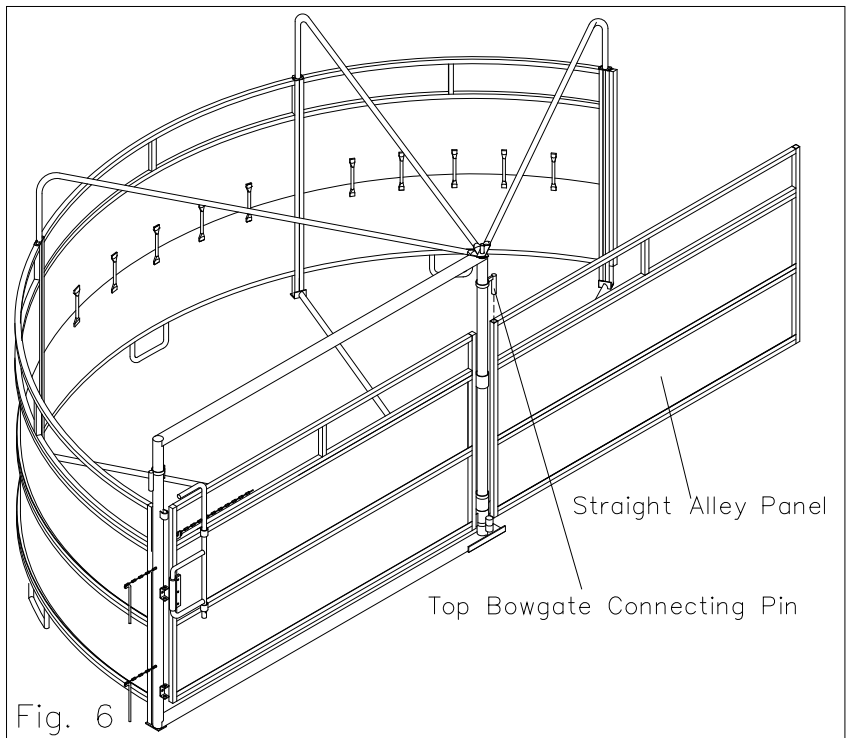

Step 7:

Unscrew the bolt at the top of the Panel Adapter and slide the top assembly out as far as possible. Hook the bottom strap under the bottom rail on the panel and telescope the top assembly down to hook onto the top rail of the panel as shown. Tighten the bolt to secure the adapter in place as shown in figures 7 and 8.

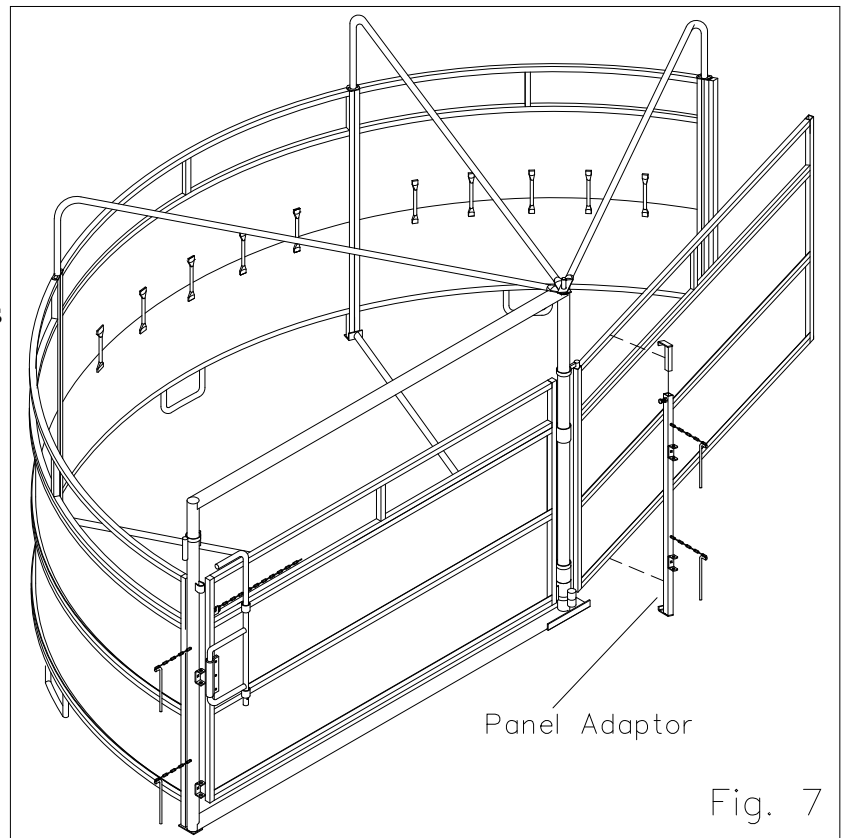

Fig. 7

Step 8:

Take three catwalk hangers per 10' Curved Sweep Panel and evenly space them along the outside of the Panels. Slide the bottom of the hangers over the lip on the outside of the panel. Then slide the other end of the hangers over the upper lip as shown in figure 8. Repeat the procedure for each of the three 10' Curved Sweep Tub Panels.

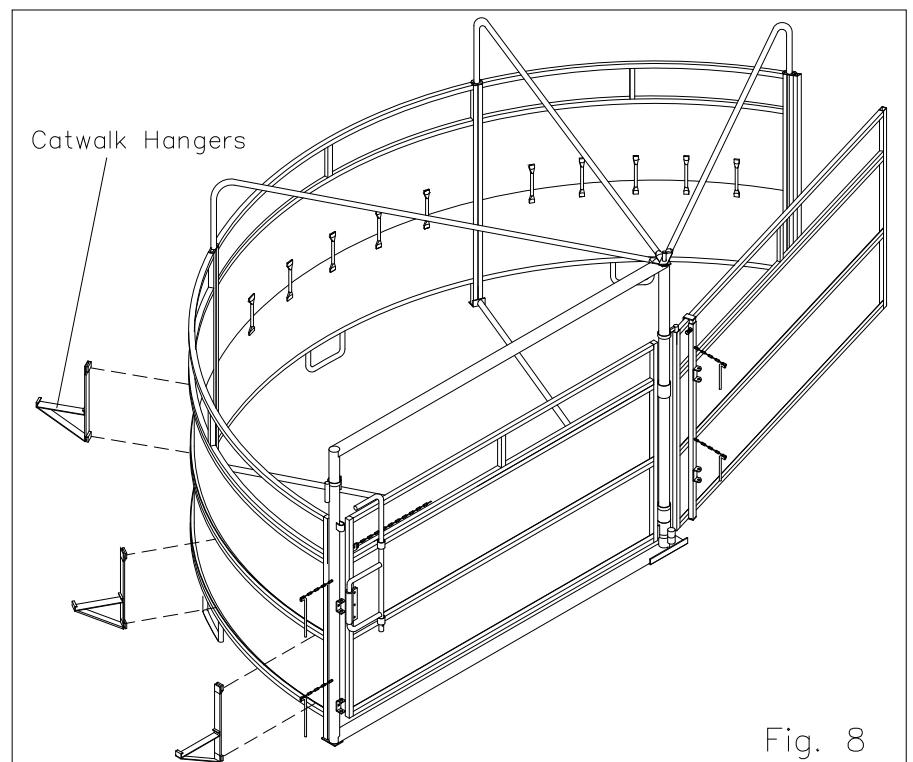

Fig. 8

Step 9:

To hang the catwalk, slide one end of the Outside Catwalk into the end of the Catwalk Hangers as shown. Using a pry bar, insert the catwalk inside each of the catwalk hangers as shown in figure 9. Repeat this for each of the three catwalks until all the catwalks are secure. Using a pry bar, place the two Catwalk Joint Plates over the ends of two meeting catwalks.

